

## F11411 COLONIAL WET FOOT

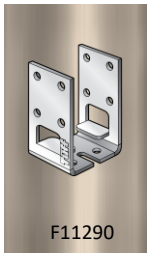
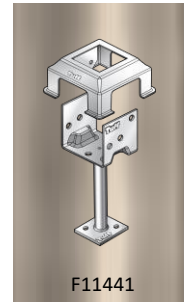
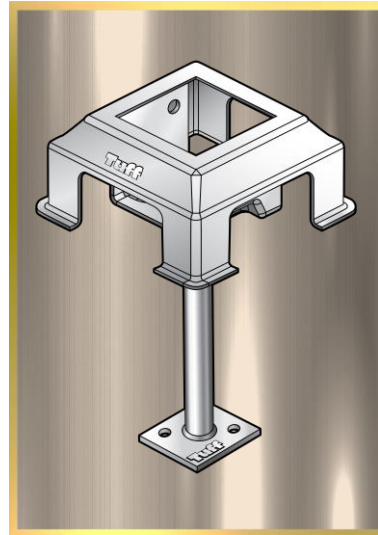
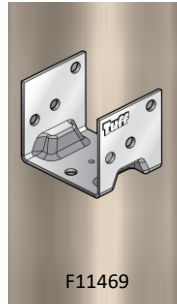
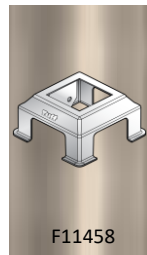

PRODUCT CODE	: F11411
BARCODE	: 9314691114115
POST SIZE	: 90MM
SHAFT LENGTH	: 100MM
SHAFT DIAMETER	: 25MM
BOLT HOLE	: M12
MADE FROM	: 2.5MM STEEL
FINISHING	: HOT DIP GALVANISED

### NOTES:

- CREATE AN ELEGANT DISTINCTIVE STYLE ON PERGOLAS, CARPORTS AND VERANDAHS
- SUITS 90MM, 100MM AND 115MM TIMBER POSTS